

Grooved angle type pressure reducing valve

Pressure reducing valve is pilot-operated pressure control valve used in sprinkler and standpipe systems. It automatically reduces a higher inlet pressure to a steady lower outlet pressure, without changing flow rate and inlet pressure.

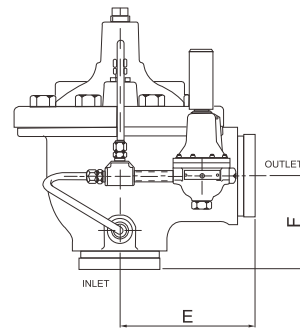

- Certificate: UL Listed
- Standard: UL 1739 / NFPA 13 / NFPA 14
- Connection: Grooved as AWWA C606
- Adjustment: 50 ~ 175 psi / 30 ~ 165 psi
- Temperature: Max 82°C, water
- W. pressure: 300 psi
- Surface: FBE coating as AWWA C550



Main parts and material

Body	Ductile iron as ASTM A536, 65-45-12	Cover	Ductile iron as ASTM A536, 65-45-12
Main valve trim	SS seat, SS stem	Pilot control	Cast bronze with SS trim

Available size

Size		Pressure adjustment (psi)	E	Connection	Working pressure (psi)	Ref. No.
Inch	DN		mm			
2"	50	30 ~ 165	121	Grooved	300	V6402
3"	80	50 ~ 175	152	Grooved	300	V6404
4"	100	50 ~ 175	191	Grooved	300	V6405