

Air release valve

Air release valve is used in wet pipe sprinkler systems and on casing of horizontal split case pump, so to automatically release small pockets of accumulated air while the system operates under pressure exceeding atmospheric pressure.

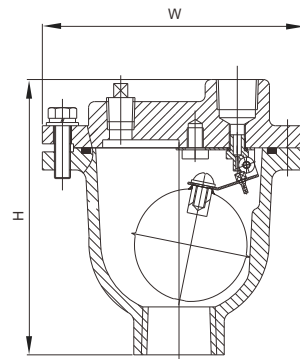

- Certificate: UL Listed / FM Approved
- Standard: UL 2573, NFPA 20, AWWA C512
- Connection: Threaded, NPT / BSPT / BSPP
- Feature: Small orifice, vent air only
- Temperature: Max 82°C, water
- W. pressure: 300 / 200 psi
- Surface: FBE coating as AWWA C550



Main parts and material

Body / bonnet	Ductile iron as ASTM A536, 65-45-12	Float	SS 304
Internal trim parts	SS 304	Seal	EPDM, Buna-N, or Viton

Available size (Source 1 with UL/FM)

Inlet	Outlet	Orifice	Dimension (mm)		Working pressure (psi)	Ref. No.
			H	W		
1/2" NPT	1/2" NPT	1/16"	149	95	300	U1701 (UL/FM)
3/4" NPT	1/2" NPT	1/16"	149	95	300	U1702 (UL/FM)
1" NPT	1/2" NPT	1/16"	149	95	300	U1703 (UL/FM)

Air release valve

Available size (Source 2 with UL/FM)

Inlet	Outlet	Orifice	Dimension (mm)		Working pressure (psi)	Ref. No.
			H	W		
1/2" NPT	1/2" NPT	1/16"	137	125	300	U1711 (UL/FM)
1/2" NPT	1/2" NPT	3/32"	137	125	300	U1712 (UL/FM)
3/4" NPT	1/2" NPT	1/16"	137	125	300	U1713 (UL/FM)
3/4" NPT	1/2" NPT	3/32"	137	125	300	U1714 (UL/FM)
1" NPT	1/2" NPT	1/16"	137	125	300	U1715 (UL/FM)
1" NPT	1/2" NPT	3/32"	137	125	300	U1716 (UL/FM)

Available size (Source 3 with FM)

Inlet	Outlet	Orifice	Dimension (mm)		Working pressure (psi)	Ref. No.
			H	W		
1/2" NPT / BSPT / BSPP	1/2" NPT	1/16"	137	125	200	U1721 (FM)
3/4" NPT / BSPT / BSPP	1/2" NPT	1/16"	137	125	200	U1722 (FM)
1" NPT / BSPT / BSPP	1/2" NPT	1/16"	137	125	200	U1723 (FM)