

Flanged NRS gate valve with post flange and wrench nut

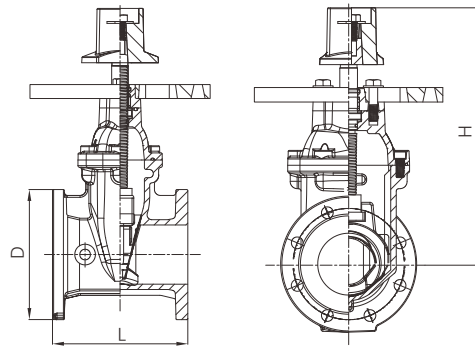

- Certificate: UL Listed / FM Approved
- Standard: UL 262 / AWWA C515, C509
- Connection: Flanged as B16.1 Class 125, B16.5 Class 150, Mechanical joint as ANSI / AWWA C153 / A21.53 etc.
- Post flange: Dia 12", PCD 10-1/2", bolt hole 4 x 3/4"
- Temperature: 0°C to 80°C
- W. pressure: 250 / 300 / 363 psi
- Surface: FBE coating as AWWA C550



Main parts and material

| | | | |
|----------------------|-------------------------------------|--------------------------------------|--|
| Body / bonnet | Ductile iron as ASTM A536, 65-45-12 | Resilient wedge disc | Ductile iron with EPDM |
| Stem | AISI304 / AISI316 / AISI420 | Post flange / wrench nut (2") | Ductile iron, and match indicator post |

Available size

| Size | | | Dimension (mm) | | Working pressure (psi) | Ref. No. |
|------|-----|-------|----------------|------|------------------------|----------|
| Inch | DN | mm | L | H | | |
| 4" | 100 | 114.3 | 229 | 395 | 300 / 363 | V4001 |
| 5" | 125 | 141.3 | 254 | 432 | 300 / 363 | V4002 |
| 6" | 150 | 168.3 | 267 | 475 | 300 / 363 | V4003 |
| 8" | 200 | 219.1 | 292 | 585 | 300 / 363 | V4004 |
| 10" | 250 | 273.0 | 330 | 656 | 300 / 363 | V4005 |
| 12" | 300 | 323.8 | 356 | 751 | 300 / 363 | V4006 |
| 14" | 350 | 355.6 | 381 | 952 | 250 | V4007 |
| 16" | 400 | 406.4 | 406 | 952 | 250 | V4008 |
| 18" | 450 | 457 | 432 | 1178 | 250 | V4009 |
| 20" | 500 | 508 | 457 | 1199 | 250 | V4010 |
| 24" | 600 | 610 | 508 | 1367 | 250 | V4011 |

Note: For size 4" to 12" with working pressure 300 psi, it is also available with flanged connection as per EN 1092-2 PN 16.