

# Flanged NRS gate valve with wrench nut

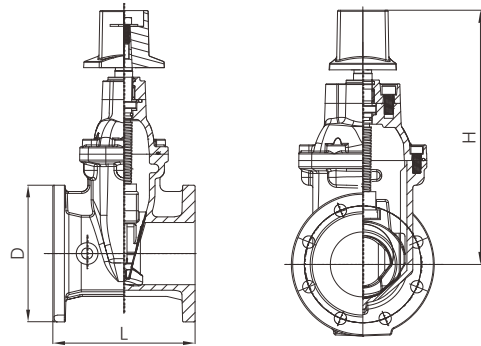

- Certificate: UL Listed
- Standard: UL 262 / AWWA C515, C509
- Connection: Flanged as B16.1 Class 125, B16.5 Class 150, Mechanical joint as ANSI / AWWA C153 / A21.53 etc.
- Temperature: 0°C to 80°C
- W. pressure: 250 / 300 psi
- Surface: FBE coating as AWWA C550



## Main parts and material

<b>Body / bonnet</b>	Ductile iron as ASTM A536, 65-45-12	<b>Resilient wedge disc</b>	Ductile iron with EPDM
<b>Stem</b>	AISI304 / AISI316	<b>Wrench nut (2")</b>	Ductile iron, and match operating key

## Available size

Size			Dimension (mm)		Working pressure (psi)	Ref. No.
Inch	DN	mm	L	H		
2"	50	60.3	178	278	300	V3701 (ISO)
2-1/2"	65	73.0	190	300	300	V3702 (UL/FM)
3"	80	88.9	203	321	300	V3703 (UL/FM)
4"	100	114.3	229	375	300	V3704 (UL/FM)
5"	125	141.3	254	415	300	V3705 (UL/FM)
6"	150	168.3	267	455	300	V3706 (UL/FM)
8"	200	219.1	292	565	300	V3707 (UL/FM)
10"	250	273.0	330	636	300	V3708 (UL/FM)
12"	300	323.8	356	731	300	V3709 (UL/FM)
14"	350	355.6	381	928	250	V3710 (UL/FM)
16"	400	406.4	406	928	250	V3711 (UL/FM)
18"	450	457	432	1165	250	V3712 (UL/FM)
20"	500	508	457	1188	250	V3713 (UL/FM)
24"	600	610	508	1364	250	V3714 (UL/FM)