

Vertical two compartment fire cabinet

Vertical fire cabinet has dual compartment for protecting both hose reel and layflat fire hose (or extinguisher). The cabinet is surface or recess mounted, with compact design for saving space and easy access for operation.

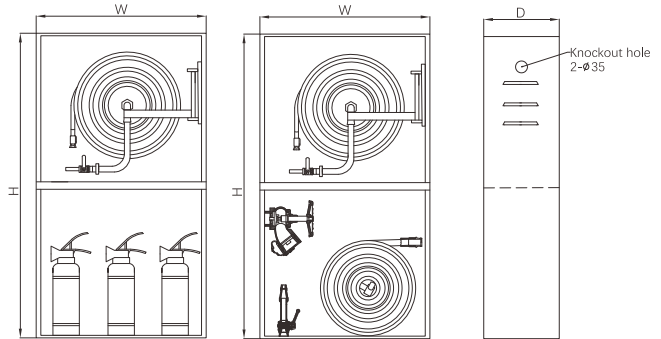

- Certificate: ISO
- Standard: Refer to BS 5041
- Capacity: Fire hose reel + layflat hose
Fire hose reel + extinguisher
- Mounting: Wall surface / recessed
- Surface: Red powder coating / bright SS



Main parts and material

Box / door	Cold rolled steel or SS, 1.0 / 1.2 / 1.5 mm thickness	Door type	Double doors, from left and right open 180°, bullet hinge or continuous piano hinge
Door glazing	Non (full solid), or acrylic viewing panel, slotted inside the door or embedded into the door with rubber raised edge	Lock	Rotary pull lock, or keyed cylinder lock

Available size

Content	Capacity	Mounting	Dimension W x H x D (mm)	Ref. No.
Swinging arm hose reel + dry powder extinguisher	19mm x 30m + 3 x 6 kg	Surface / recessed	700 x 1400 x 250	FE9701
Swinging arm hose reel + dry powder extinguisher	25mm x 30m + 3 x 6 kg	Surface / recessed	700 x 1400 x 270	FE9702
Swinging arm hose reel + landing valve & layflat hose with branchpipe	25mm x 30m + 2.5" & 2.5" x 30m	Surface / recessed	800 x 1600 x 300	FE9703
Swinging arm hose reel + DP extinguisher & layflat hose with branchpipe	25mm x 30m + 1 x 6 kg & 2.5" x 30m	Surface / recessed	800 x 1600 x 300	FE9704

Note:

1. For recessed type, it contains projection trim on the external face of cabinet with width 38mm.
2. Cabinet can be LPCB approved if it contains LPCB approved fire hose reel.