

Dry landing valve cabinet

Dry landing valve cabinet (dry riser outlet box) protects dry landing valve from contamination & damage. The cabinet is recessed in a wall, and water is obtained from the outlet.

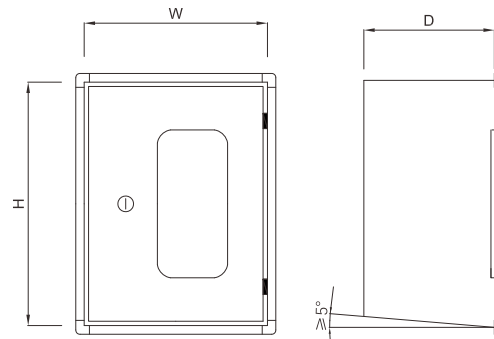

- Certificate: ISO
- Standard: BS 5041-4
- Capacity: Dry landing valve
- Mounting: Recessed
- Surface: Red powder coating / bright SS



Main parts and material

Box / door	Cold roll steel or SS, 1.2mm thick	Door type	Single door, from left to right open 180°, bullet hinge or continuous piano hinge
Door glazing	Wire glass 6mm thick, slotted inside the door or embedded into the door with rubber raised edge	Lock	Keyed cylinder lock, can be released from the inside without the key

Available size

Content	Capacity	Mounting	Dimension W x H x D (mm)	Ref. No.
Dry landing valve	DN 65	Recessed	400 x 600 x 300	FE9101

Note:

1. It contains projection trim on the external face of cabinet with width 25mm.
2. The rear of the cabinet has pre-cut hole for easy connection to the pipeline.
3. The bottom of cabinet has a fall towards the front around 5°, with 2 holes of $\phi 10\text{mm}$ for drainage.