

# Grooved swing check valve

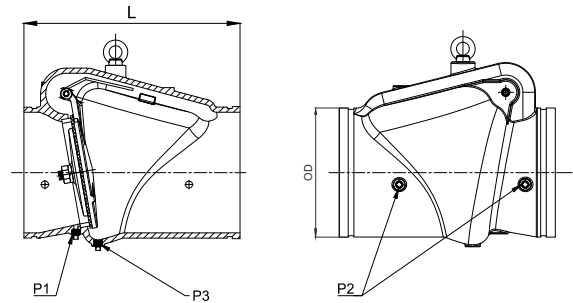

- Certificate: UL Listed / FM Approved
- Standard: UL 312, AWWA C508
- Connection: Grooved as AWWA C606
- Temperature: 0°C to 80°C
- W. pressure: 300 / 363 psi
- Surface: FBE coating as AWWA C550



## Main parts and material

<b>Body / disc</b>	Ductile iron as ASTM A536, 65-45-12	<b>Body seat ring</b>	2" to 4", AISI304 with EPDM; 5" to 12", ductile iron with EPDM
<b>Spring</b>	SS304	<b>Plug sealing</b>	EPDM

## Available size

Size			Length L (mm)	NPT (BSPT) plug		Working pressure (psi)	Ref. No.
Inch	DN	mm		P1 / P3	P2		
2"	50	60.3	171	1/2"	3/8"	300 / 363	V5201
2-1/2"	65	73.0 / 76.1	184	1/2"	3/8"	300 / 363	V5202
3"	80	88.9	197	1/2"	3/8"	300 / 363	V5203
4"	100	114.3	210	1/2"	1/2"	300 / 363	V5204
5"	125	141.3 / 139.7	248	1/2"	1/2"	300 / 363	V5205
6"	150	168.3 / 165.1	324	1/2"	1/2"	300 / 363	V5206
8"	200	219.1	371	1/2"	1/2"	300 / 363	V5207
10"	250	273.0	457	1/2"	1/2"	300 / 363	V5208
12"	300	323.8	535	1/2"	1/2"	300 / 363	V5209