

Grooved NRS gate valve with post flange and wrench nut

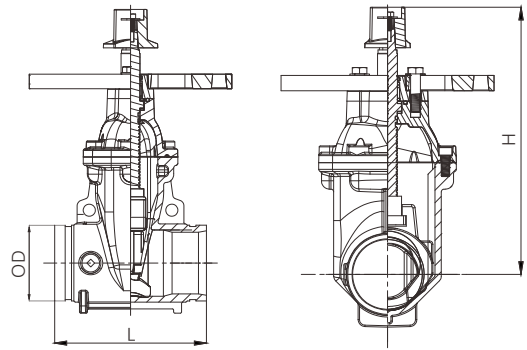

- Certificate: UL Listed / FM Approved
- Standard: UL 262 / AWWA C515, C509
- Connection: Grooved as AWWA C606
- Post flange: Dia 12", PCD 10-1/2", bolt hole 4 x 3/4"
- Temperature: 0°C to 80°C
- W. pressure: 300 psi
- Surface: FBE coating as AWWA C550



Main parts and material

Body / bonnet	Ductile iron as ASTM A536, 65-45-12	Resilient wedge disc	Ductile iron with EPDM
Stem	AISI304 / AISI316	Post flange / wrench nut (2")	Ductile iron, and match indicator post

Available size

Size			Dimension (mm)		Working pressure (psi)	Ref. No.
Inch	DN	mm	L	H		
4"	100	114.3	229	395	300	V4101
5"	125	141.3 / 139.7	254	432	300	V4102
6"	150	168.3 / 165.1	267	475	300	V4103
8"	200	219.1	292	585	300	V4104
10"	250	273.0	330	656	300	V4105
12"	300	323.8	356	751	300	V4106