

Flanged x Grooved NRS gate valve

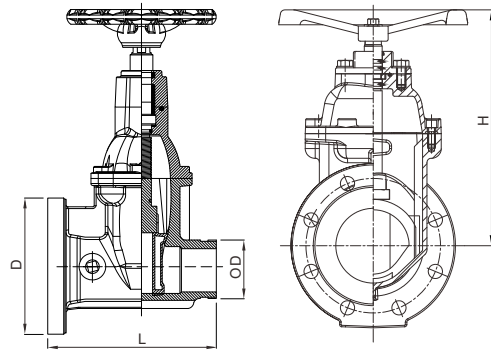

- Certificate: UL Listed / FM Approved
- Standard: UL 262 / AWWA C515, C509
- Connection: Flanged as B16.1 Class 125 / B16.5 Class 150 + Grooved as AWWA C606
- Temperature: 0°C to 80°C
- W. pressure: 300 psi
- Surface: FBE coating as AWWA C550



Main parts and material

Body / bonnet / handwheel	Ductile iron as ASTM A536, 65-45-12	Resilient wedge disc	Ductile iron with EPDM
Stem	AISI304 / AISI316	Tapping plug	Bronze as ASTM B584, 3/8" NPT for 2" ~ 3"; 1/2" NPT for 4" ~ 5"; 3/4" NPT for 6" ~ 12"

Available size

Inch	Size		Dimension (mm)		Working pressure (psi)	Ref. No.
	DN	mm	L	H		
2"	50	60.3	178	254	300	V3601 (FM)
2-1/2"	65	73.0 / 76.1	190	275	300	V3602 (UL/FM)
3"	80	88.9	203	301	300	V3603 (UL/FM)
4"	100	114.3	229	355	300	V3604 (UL/FM)
5"	125	141.3 / 139.7	254	393	300	V3605 (UL)
6"	150	168.3 / 165.1	267	448	300	V3606 (UL/FM)
8"	200	219.1	292	548	300	V3607 (UL/FM)
10"	250	273.0	330	626	300	V3608 (UL/FM)
12"	300	323.8	356	722	300	V3609 (UL/FM)

Note: It is also available with flanged connection as per EN 1092-2 PN 16.