

## Flanged x Grooved OS&Y gate valve

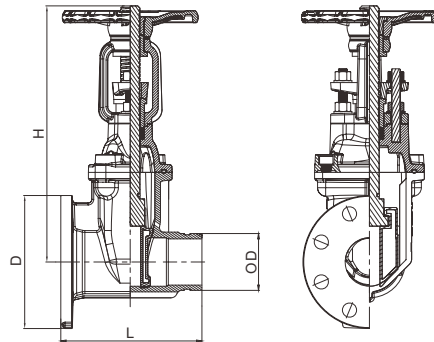

- Certificate: UL Listed / FM Approved
- Standard: UL 262 / AWWA C515, C509
- Connection: Flanged as B16.1 Class 125, B16.5 Class 150, etc.
- Temperature: 0°C to 80°C
- W. pressure: 300 psi
- Surface: FBE coating as AWWA C550



### Main parts and material

<b>Body / bonnet / yoke / handwheel</b>	Ductile iron as ASTM A536, 65-45-12	<b>Resilient wedge disc</b>	Ductile iron with EPDM
<b>Stem</b>	AISI304 / AISI316 / AL-bronze	<b>Tapping plug</b>	Bronze as ASTM B584, 3/8" NPT for 2" ~ 3"; 1/2" NPT for 4" ~ 5"; 3/4" NPT for 6" ~ 12"

### Available size

Size			Dimension (mm)			Working pressure (psi)	Ref. No.
Inch	DN	mm	L	H min	H max		
2"	50	60.3	178	348	400	300	V3301
2-1/2"	65	73.0 / 76.1	190	373	440	300	V3302
3"	80	88.9	203	408	490	300	V3303
4"	100	114.3	229	471	573	300	V3304
5"	125	141.3 / 139.7	254	541	665	300	V3305
6"	150	168.3 / 165.1	267	601	755	300	V3306
8"	200	219.1	292	774	975	300	V3307
10"	250	273.0	330	1029	1283	300	V3308
12"	300	323.8	356	1065	1370	300	V3309

**Note:** It is also available with flanged connection as per EN 1092-2 PN 16.