

Flanged swing check valve

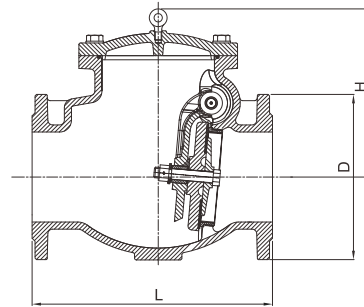

- Certificate: UL Listed / FM Approved
- Standard: EN 1074-3
- Connection: Flanged as EN 1092-2
- Temperature: 0°C to 80°C
- W. pressure: PN 16 / PN 25
- Surface: FBE coating as AWWA C550



Main parts and material

Body / bonnet	Ductile iron as EN 1563, EN-GJS-450-10	Disc / clapper arm	Ductile iron with EPDM
Seat ring	Bronze	Eye bolt	Carbon steel zinc plated, for lifting size 4" and above

Available size

Size			Dimension (mm)		Working pressure	Ref. No.
Inch	DN	mm	L	H		
2"	50	60.3	203	133	PN 16 / PN 25	V2101
2-1/2"	65	76.1	216	150	PN 16 / PN 25	V2102
3"	80	88.9	241	150	PN 16 / PN 25	V2103
4"	100	114.3	292	218	PN 16 / PN 25	V2104
5"	125	139.7	330	245	PN 16 / PN 25	V2105*
6"	150	165.1	356	290	PN 16 / PN 25	V2106
8"	200	219.1	495	330 / 355	PN 16 / PN 25	V2107
10"	250	273.0	622	350	PN 16	V2108
12"	300	323.9	698	376	PN 16	V2109

Note: * For size 5" with working pressure PN 16, it is only FM approved, not UL listed.