

# Flanged NRS gate valve with post flange and stem cap

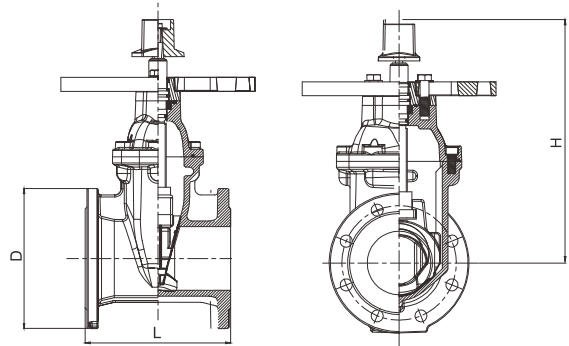

- Certificate: UL Listed / FM Approved
- Standard: BS EN 1074-2
- Connection: Flanged as EN 1092-2
- Temperature: 0°C to 80°C
- W. pressure: PN 16
- Surface: FBE coating as AWWA C550



## Main parts and material

|                      |  |                               |  |
|----------------------|--|-------------------------------|--|
| <b>Body / bonnet</b> | Ductile iron as EN 1563, EN-GJS-450-10 | <b>Resilient wedge disc</b>   | Ductile iron with EPDM                 |
| <b>Stem</b>          | SS304 / SS316                          | <b>Post flange / stem cap</b> | Ductile iron, and match indicator post |

## Available size

| Size |     |       | Dimension (mm) |     | Working pressure | Ref. No. |
|------|-----|-------|----------------|-----|------------------|----------|
| Inch | DN  | mm    | L              | H   |                  |          |
| 4"   | 100 | 114.3 | 229            | 347 | PN 16            | V0801    |
| 5"   | 125 | 139.7 | 254            | 432 | PN 16            | V0802    |
| 6"   | 150 | 165.1 | 267            | 443 | PN 16            | V0803    |
| 8"   | 200 | 219.1 | 292            | 518 | PN 16            | V0804    |
| 10"  | 250 | 273.0 | 330            | 656 | PN 16            | V0805    |
| 12"  | 300 | 323.9 | 356            | 751 | PN 16            | V0806    |