

# Flanged NRS gate valve with stem cap

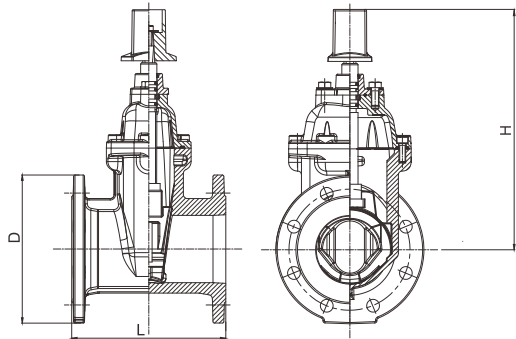

- Certificate: UL Listed
- Standard: BS 5163
- Connection: Flanged as EN 1092-2
- Temperature: 0°C to 80°C
- W. pressure: PN 16
- Surface: FBE coating as AWWA C550



## Main parts and material

<b>Body / bonnet</b>	Ductile iron as EN 1563, EN-GJS-450-10	<b>Resilient wedge disc</b>	Ductile iron with EPDM
<b>Stem</b>	SS304 / SS316	<b>Stem cap</b>	Ductile iron, and match operating key

## Available size

Size			Dimension (mm)		Working pressure	Ref. No.
Inch	DN	mm	L	H		
2"	50	60.3	178	241	PN 16	V0701 (ISO)
2-1/2"	65	76.1	190	255	PN 16	V0702 (UL)
3"	80	88.9	203	304	PN 16	V0703 (UL)
4"	100	114.3	229	337	PN 16	V0704 (UL)
5"	125	139.7	254	404	PN 16	V0705 (UL)
6"	150	165.1	267	436	PN 16	V0706 (UL)
8"	200	219.1	292	443	PN 16	V0707 (UL)
10"	250	273.0	330	641	PN 16	V0708 (UL)
12"	300	323.9	356	743	PN 16	V0709 (UL)
14"	350	355.6	381	1364	PN 16	V0710 (UL)
16"	400	406.4	406	1364	PN 16	V0711 (UL)
18"	450	457	432	1364	PN 16	V0712 (UL)
20"	500	508	457	1364	PN 16	V0713 (UL)
24"	600	610	508	1364	PN 16	V0714 (UL)

V07 /