

Flanged x Grooved OS&Y gate valve

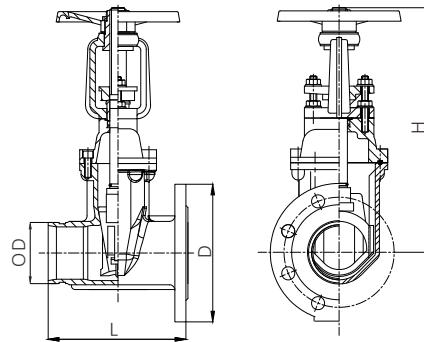

- Certificate: UL Listed / FM Approved
- Standard: BS EN 1074-2
- Connection: Flanged as EN 1092-2 + Grooved as ISO 6182
- Temperature: 0°C to 80°C
- W. pressure: PN 16
- Surface: FBE coating as AWWA C550



Main parts and material

Body / bonnet / yoke / handwheel	Ductile iron as EN 1563, EN-GJS-450-10	Resilient wedge disc	Ductile iron with EPDM
Stem	SS304 / SS316	Locknut	Carbon steel, zinc plated

Available size

Size			Dimension (mm)			Working pressure	Ref. No.
Inch	DN	mm	L	H min	H max		
2"	50	60.3	178	323	373	PN 16	V0301
2-1/2"	65	76.1 / 73.0	190	343	408	PN 16	V0302
3"	80	88.9	203	370	450	PN 16	V0303
4"	100	114.3	229	442	542	PN 16	V0304
5"	125	139.7 / 141.3	254	541	665	PN 16	V0305
6"	150	165.1 / 168.3	267	608	758	PN 16	V0306
8"	200	219.1	292	720	920	PN 16	V0307
10"	250	273.0	330	939	1193	PN 16	V0308
12"	300	323.9	356	1065	1370	PN 16	V0309